



THOMAS GUNN navigation services
SERVING THE SHIPPING INDUSTRY WORLDWIDE

Signalling & Sounding Equipment for Commercial Vessels



Signalling & Sounding Equipment For Commercial Vessels



Bell

Brass bell, 12" (300mm) dia, supplied complete with DOT Certificate for vessels of 20 metres or more. Complies with the requirements of the International Collision regulations. May be supplied engraved with ship's name, year of build etc. as required.

Stock No BEL 006

Brass bell, 8" (200mm) dia, supplied with bracket and DOT Certificate for vessels under 20 metres. Complies with the requirements of the International Collision Regulations. May be supplied engraved with ship's name, year of build etc. as required.

Stock No BEL 005

Fog Gong

Zinc plated steel, 410mm dia, supplied with beater and DOT Certificate. Complies with the requirements of the International Collision Regulations. May be supplied engraved with ship's name year of build etc, as required.

Stock No SIG 005

Fog Horn

Norwegian pattern type, mechanical

Stock No SIG 007

Loud Hailer

Battery operated, range up to 0.6km, batteries 8 x Size C (not included). Output 5w rms/16w max

Stock No SIG 008



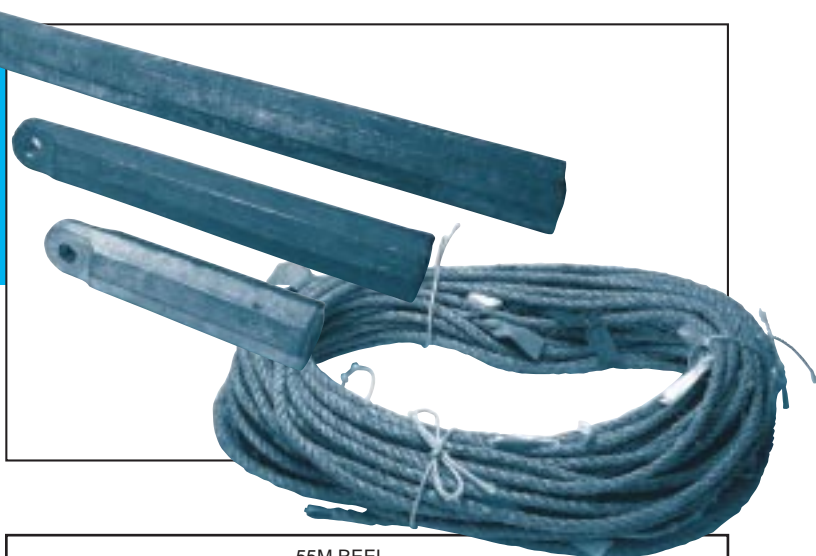

Sounding Equipment

Lead Weight 3.2kg Stock No SOU 001

Lead Weight 6.4kg Stock No SOU 002

Lead Weight 12.8kg Stock No SOU 003

Lead Line 220m, best manilla, graduated at 10m intervals

Stock No SOU 004

Lead Line 55m, best manilla, graduated at 2m intervals

Stock No SOU 005

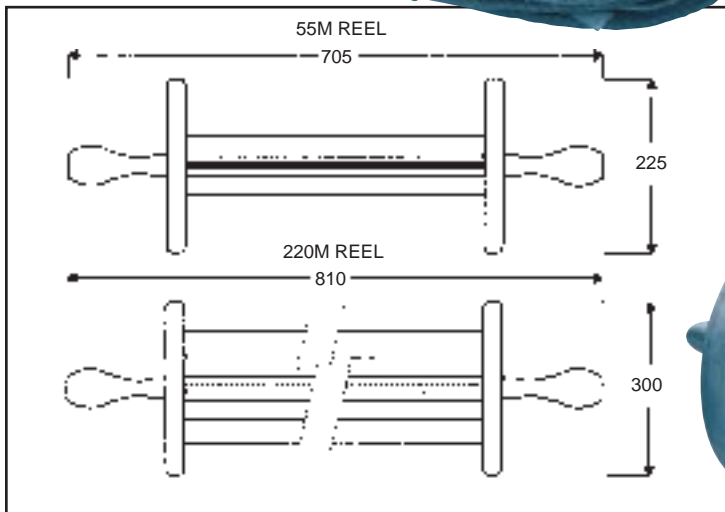

Wooden Reel

Stock No SOU 006 For 220m Lead Line

Stock No SOU 007 For 55m Lead Line

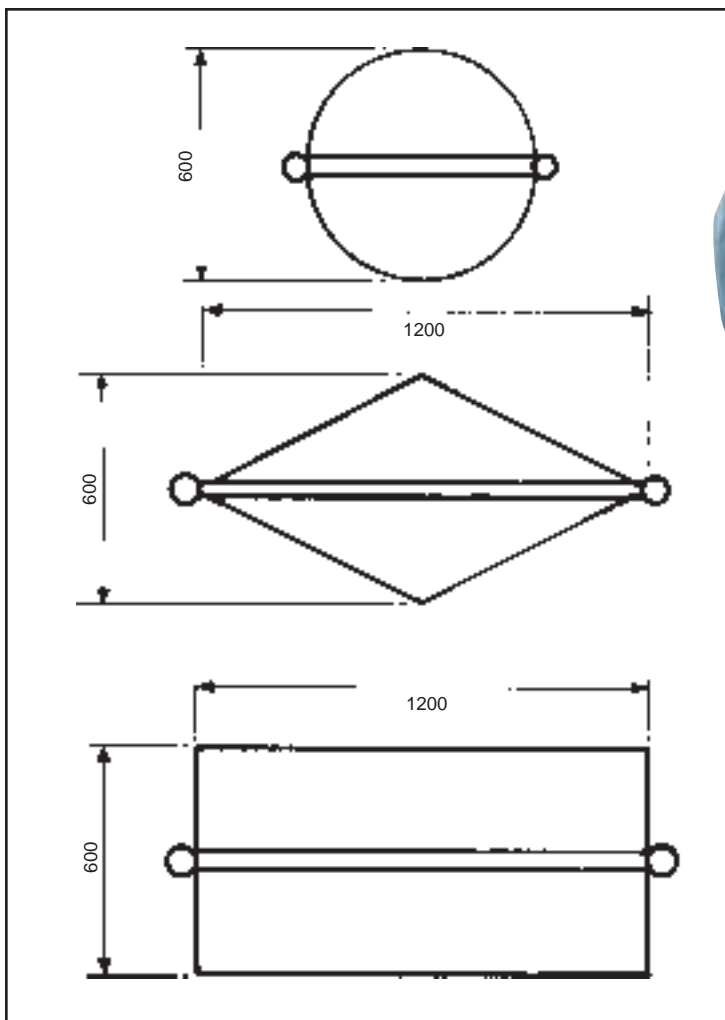
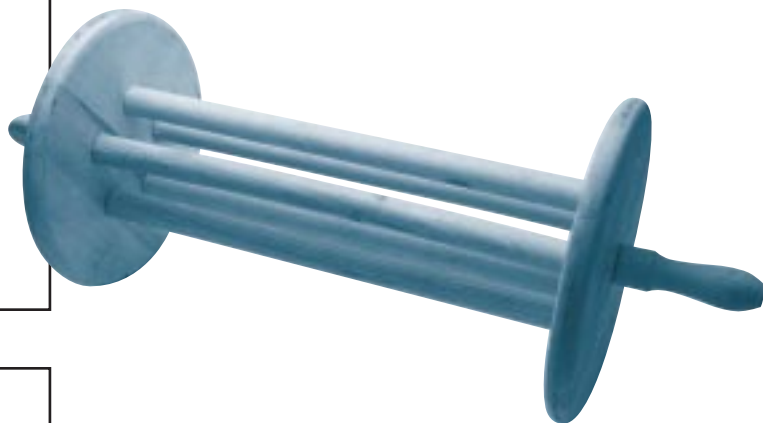

Signalling shapes

Folding type complying with International Collision Regulations, canvas construction.

Stock No SIG 001 Black Cylinder

Stock No SIG 002 Black Diamond

Stock No SIG 003 Black ball

THOMAS GUNN navigation services established in 1978, is a family concern with a long term commitment to Quality Management where satisfying our customers needs is the first priority of all employees. The company is represented in the major marine markets worldwide offering a wide range of products and services including:



Supply to the SOLAS regulated market a comprehensive management service that ensures the maintenance of charts and nautical publications in compliance with the ISM code, thereby aiding safe navigation.

Complete worldwide coverage of British Admiralty Charts & Publications.

Extensive stocks of other Hydrographic Charts & Publications including U.S., N.Z., and Australian, together with full range of Marine Technical Publications.

Computerised new edition service including weekly notices to mariners and chart correction tracings, weekly chart correction lists and compilation of ships indexes.



Supply and updating service for Admiralty raster chart services and vector including approved software systems.

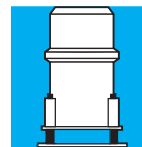

Distributor and service centre for S.G. Brown gyros and associated products.

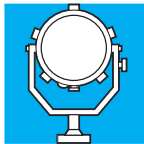

Distribution of wide range of marine lighting including safety lights, navigation lights, searchlights, signalling lights, floodlights and associated products.



Adjusting and repair of Compasses by MCA certified compass adjusters.



Distributor of nautical instruments including anemometers, bells, barometers, binoculars, clinometers, clocks, shapes and sextants.

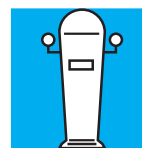

Distribution of magnetic compasses and binnacles, TMC systems and off course alarms and a wide range of associated items.



THOMAS GUNN navigation services

SERVING THE SHIPPING INDUSTRY WORLDWIDE